

4 3 2 1

ZONE	REV.	REVISION DESCRIPTION	ECN NO.	DATE
	K	RE-DOC IN DWGEDITOR NOTE 1 WAS "CERTIFICATE OF TEST REPORT REQUIRED FOR THREAD INSPECTION TEST RESULTS" DELETE NOTE 2 (SAMPLE OF NUT TO ACCOMPANY...),RENUMBER NOTE 3; PD	ECN0051987	02-JUN-2009

D

D

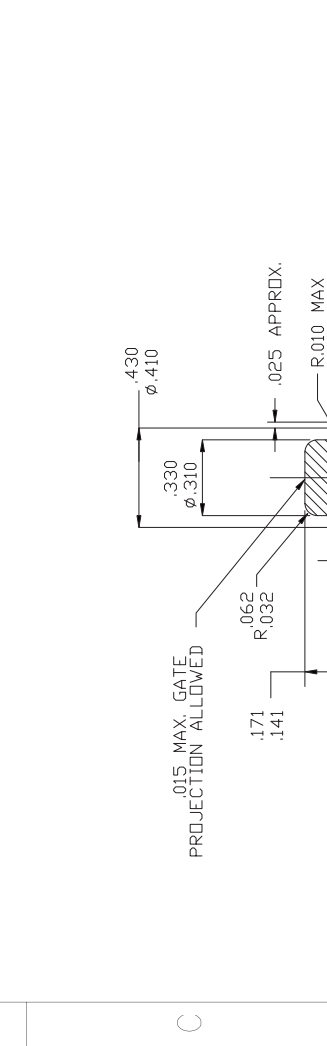
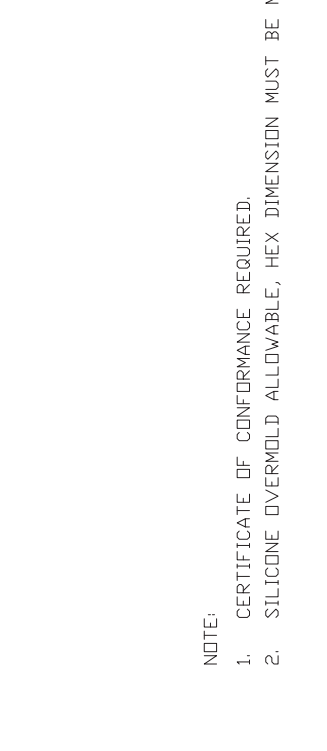
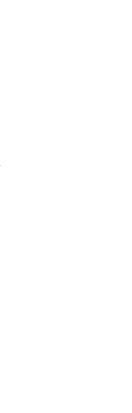
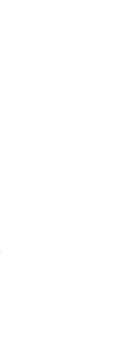

C

NOTE:

1. CERTIFICATE OF CONFORMANCE REQUIRED.
2. SILICONE OVERMOLD ALLOWABLE, HEX DIMENSION MUST BE MAINTAINED.

C

B

B

FOR REFERENCE ONLY, CHECK LATEST REVISION BEFORE USE

145000-1

PART NO.

BOOT: SILICONE RUB-R-GLASS, PER SPEC ZZR-765 CLASS III, DUROMETER 50-60  
MOUNTING NUT: BRASS PER SPEC OO8626, COMP 22, NICKEL PLATE PER SPEC OON290 CLASS II

FOR REFERENCE ONLY, CHECK LATEST REVISION BEFORE USE

145000-1

PART NO.

BOOT: SILICONE RUB-R-GLASS, PER SPEC ZZR-765 CLASS III, DUROMETER 50-60  
MOUNTING NUT: BRASS PER SPEC OO8626, COMP 22, NICKEL PLATE PER SPEC OON290 CLASS II

FOR REFERENCE ONLY, CHECK LATEST REVISION BEFORE USE  
PARTS MADE TO THIS PRINT MUST CONFORM TO E9898 REV. E  
SENSATA TECHNOLOGIES PROPRIETARY AND CONFIDENTIAL. NEITHER THIS PRINT NOR THE INFORMATION CONTAINED HEREON IS TO BE USED OR AGAINST THE INTERESTS OF ANY OF ITS AFFILIATED COMPANIES OR VENDORS.  
UNLESS OTHERWISE SPECIFIED, DIMENSIONS ARE IN INCHES  
TOLERANCES ANGLES  
DECIMALS

145000-1  
PART NO.  
MATERIAL

FOR REFERENCE ONLY, CHECK LATEST REVISION BEFORE USE  
PARTS MADE TO THIS PRINT MUST CONFORM TO E9898 REV. E  
SENSATA TECHNOLOGIES PROPRIETARY AND CONFIDENTIAL. NEITHER THIS PRINT NOR THE INFORMATION CONTAINED HEREON IS TO BE USED OR AGAINST THE INTERESTS OF ANY OF ITS AFFILIATED COMPANIES OR VENDORS.  
UNLESS OTHERWISE SPECIFIED, DIMENSIONS ARE IN INCHES  
TOLERANCES ANGLES  
DECIMALS

145000-1  
PART NO.  
MATERIAL

FOR REFERENCE ONLY, CHECK LATEST REVISION BEFORE USE  
PARTS MADE TO THIS PRINT MUST CONFORM TO E9898 REV. E  
SENSATA TECHNOLOGIES PROPRIETARY AND CONFIDENTIAL. NEITHER THIS PRINT NOR THE INFORMATION CONTAINED HEREON IS TO BE USED OR AGAINST THE INTERESTS OF ANY OF ITS AFFILIATED COMPANIES OR VENDORS.  
UNLESS OTHERWISE SPECIFIED, DIMENSIONS ARE IN INCHES  
TOLERANCES ANGLES  
DECIMALS

145000-1  
PART NO.  
MATERIAL

FOR REFERENCE ONLY, CHECK LATEST REVISION BEFORE USE  
PARTS MADE TO THIS PRINT MUST CONFORM TO E9898 REV. E  
SENSATA TECHNOLOGIES PROPRIETARY AND CONFIDENTIAL. NEITHER THIS PRINT NOR THE INFORMATION CONTAINED HEREON IS TO BE USED OR AGAINST THE INTERESTS OF ANY OF ITS AFFILIATED COMPANIES OR VENDORS.  
UNLESS OTHERWISE SPECIFIED, DIMENSIONS ARE IN INCHES  
TOLERANCES ANGLES  
DECIMALS

145000-1  
PART NO.  
MATERIAL

FOR REFERENCE ONLY, CHECK LATEST REVISION BEFORE USE  
PARTS MADE TO THIS PRINT MUST CONFORM TO E9898 REV. E  
SENSATA TECHNOLOGIES PROPRIETARY AND CONFIDENTIAL. NEITHER THIS PRINT NOR THE INFORMATION CONTAINED HEREON IS TO BE USED OR AGAINST THE INTERESTS OF ANY OF ITS AFFILIATED COMPANIES OR VENDORS.  
UNLESS OTHERWISE SPECIFIED, DIMENSIONS ARE IN INCHES  
TOLERANCES ANGLES  
DECIMALS

145000-1  
PART NO.  
MATERIAL

FOR REFERENCE ONLY, CHECK LATEST REVISION BEFORE USE  
PARTS MADE TO THIS PRINT MUST CONFORM TO E9898 REV. E  
SENSATA TECHNOLOGIES PROPRIETARY AND CONFIDENTIAL. NEITHER THIS PRINT NOR THE INFORMATION CONTAINED HEREON IS TO BE USED OR AGAINST THE INTERESTS OF ANY OF ITS AFFILIATED COMPANIES OR VENDORS.  
UNLESS OTHERWISE SPECIFIED, DIMENSIONS ARE IN INCHES  
TOLERANCES ANGLES  
DECIMALS

145000-1  
PART NO.  
MATERIAL

FOR REFERENCE ONLY, CHECK LATEST REVISION BEFORE USE  
PARTS MADE TO THIS PRINT MUST CONFORM TO E9898 REV. E  
SENSATA TECHNOLOGIES PROPRIETARY AND CONFIDENTIAL. NEITHER THIS PRINT NOR THE INFORMATION CONTAINED HEREON IS TO BE USED OR AGAINST THE INTERESTS OF ANY OF ITS AFFILIATED COMPANIES OR VENDORS.  
UNLESS OTHERWISE SPECIFIED, DIMENSIONS ARE IN INCHES  
TOLERANCES ANGLES  
DECIMALS

145000-1  
PART NO.  
MATERIAL



TITLE  
PUSHBUTTON  
BOOT

SIZE	DWG NO.	REV.
B	14500-1	K

SCALE	NA	AUTOCAD	SHEET 1 OF 1
-------	----	---------	--------------

PROJECT:

DEVICE: 2

PROJECT: 1

1

2

3

4

1

2

3

4

1

2

3

4

1

2

3

4

1

2

3

4

1

2

3

4

1

2

3

4

1

2

3

4

1

2

3

4

1

2

3

4

1

2

3

4

1

2

3

4

1

2

3

4

1

2

3

4

1

2

3

4

1

2

3

4

1

2

3

4

1

2

3

4

1

2

3

4

1

2

3

4

1

2

3

4

1

2

3

4

1

2

3

4

1

2

3

4

1

2

3

4

1

2

3

4

1

2

3

4

1

2

3

4

1

2

3

4

1

2

3

4

1

2

3

4

1

2

3

4

1

2

3

4

1

2

3

4

1

2

3

4

1

2

3

4

1

2

3

4

1

2

3

4

1

2

3

4

1

2

3

4

1

2

3

4

1

2

3

4

1

2

3

4

1

2

3

4

1

2

3

4

1

2

3

4

1

2

3

4

1

2

3

4

1

2

3

4

1

2

3

4

1

2

3

4

1

2

3

4

1

2

3

4

1

2

3

4

1

2

3

4

1

2

3

4

1